

C600S Microturbine

High-pressure Natural Gas, ICHP

The Signature Series Microturbine provides ultra-low emissions and reliable electrical/thermal generation from natural gas.

Benefits

- Ultra-low emissions
- One moving part – minimal maintenance and downtime
- Patented air bearings – no lubricating oil or coolant
- Integrated utility synchronization – no external switchgear
- Compact modular design allows for easy, low-cost installation
- High electrical efficiency over a very wide operating range
- High availability – part load redundancy
- Remote monitoring and diagnostic capabilities
- Proven technology with tens of millions of operating hours
- Various Factory Protection Plans available



C600S ICHP Power Package

Electrical Performance⁽¹⁾

Electrical Power Output	600kW
Voltage	400/480 VAC
Electrical Service	3-Phase, 4 Wire Wye
Frequency	50/60 Hz
Electrical Efficiency LHV	33%

Fuel/Engine Characteristics⁽¹⁾

Natural Gas HHV ⁽²⁾	30.7–47.5 MJ/m ³ (825–1,275 BTU/scf)
Inlet Pressure	517–551 kPa gauge (75–80 psig)
Fuel Flow HHV	7,200 MJ/hr (6,840,000 BTU/hr)
Net Heat Rate LHV	10.9 MJ/kWh (10,300 BTU/kWh)

Exhaust Characteristics⁽¹⁾

NOx Emissions @ 15% O ₂	< 9 ppmvd (18 mg/m ³)
Exhaust Mass Flow	4.0 kg/s (8.8 lbm/s)
Exhaust Gas Temperature	280°C (535°F) (Heat Recovery Bypassed)

**Smarter Energy
for a Cleaner Future**

Dimensions & Weight⁽³⁾

Width x Depth x Height	3.0 x 5.8 x 4.0 m (117 x 230 x 157 in)
Weight - Grid Connect Model, dry	13,700 kg (30,000 lbs)
Weight - Dual Mode Model, dry	15,800 kg (34,900 lbs)

Minimum Clearance Requirements⁽⁴⁾

Horizontal Clearance	
Left	1.5 m (60 in)
Right	0.0 m (0 in)
Front	1.7 m (65 in)
Rear	2.2 m (85 in)

ICHP Heat Recovery⁽⁵⁾

Hot Water Heat Recovery	0.9 MW (3.1 MMBtu/hr)
-------------------------	-----------------------

Certifications

- UL 2200 Listed
- CE Certified
- Certified to the following grid interconnections standards: UL 1741-SA, VDE, BDEW, CEI 0-16, AS4777
- Compliant to California Rule 21

C200 Engine Components

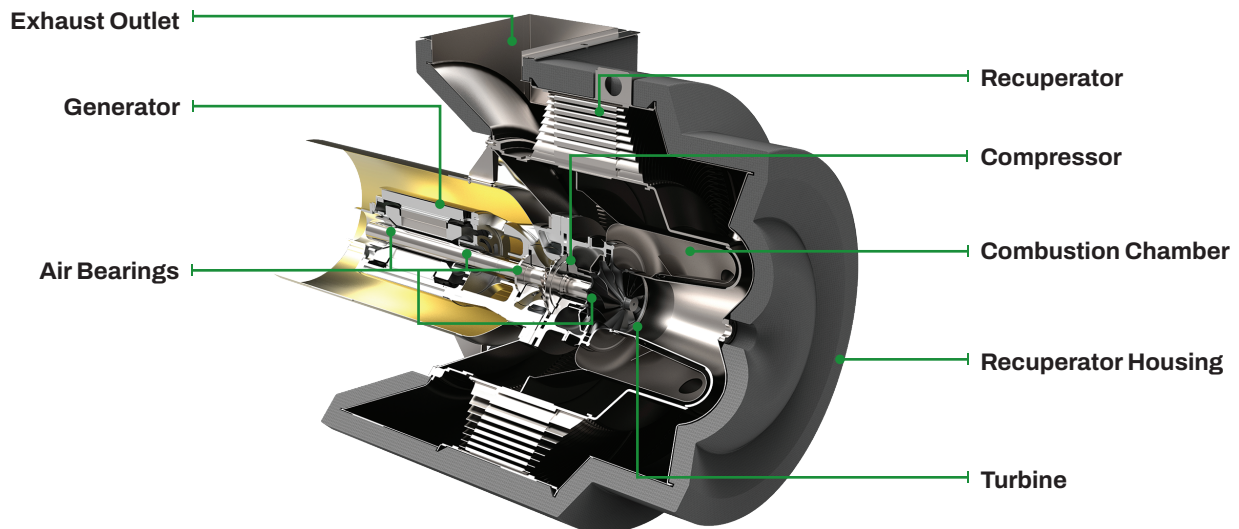

(1) Nominal full power performance at ISO conditions: 15°C (59°F), 14.696 psia, 60% RH

(2) Suitable for use with fuel blends containing up to 30 percent hydrogen gas by volume

(3) Approximate dimensions and weights

(4) Clearance requirements may increase due to local code considerations

(5) Nominal heat recovery using 3 Heat Recovery Modules (HRM). Inlet water temperature of 38°C (100°F) and flow rate of 6.3 l/s (100 gpm) per HRM

Specifications are not warranted and are subject to change without notice.