

C800S Megawatt Power Package

Low-pressure Natural Gas



The Signature Series Microturbine provides 800kW of reliable electrical power in one small, ultra-low emission, and highly efficient package.

- + Ultra-low emissions
- + One moving part – minimal maintenance and downtime
- + Patented air bearings – no lubricating oil or coolant
- + Integrated utility synchronization – no external switchgear
- + Internal fuel gas compressor housed within enclosure
- + Compact modular design allows for easy, low-cost installation
- + High electrical efficiency over a very wide operating range
- + High availability – part load redundancy
- + Remote monitoring and diagnostic capabilities
- + Proven technology with tens of millions of operating hours
- + Various Factory Protection Plans available



C800S Power Package

Electrical Performance⁽¹⁾

Electrical Power Output	760kW
Voltage	400/480 VAC
Electrical Service	3-Phase, 4 Wire Wye
Frequency	50/60 Hz
Electrical Efficiency LHV	31%

Fuel/Engine Characteristics⁽¹⁾

Natural Gas HHV	35.4–42.8 MJ/m ³ (950–1,150 BTU/scf)
Inlet Pressure	1.7–34.5 kPa gauge (0.25–5.0 psig)
Fuel Flow HHV	9,600 MJ/hr (9,120,000 BTU/hr)
Net Heat Rate LHV	46.4 MJ/kWh (44,000 BTU/kWh)

Exhaust Characteristics⁽¹⁾

NO _x Emissions @ 15% O ₂	< 9 ppmvd (18 mg/m ³)
Exhaust Mass Flow	5.3 kg/s (11.7 lbm/s)
Exhaust Gas Temperature	280°C (535°F)

Dimensions & Weight⁽²⁾

Width x Depth x Height ⁽³⁾	3.0 x 9.1 x 2.9 m (117 x 360 x 114 in)
Weight - Grid Connect Model	16,700 kg (36,800 lbs)
Weight - Dual Mode Model	19,500 kg (43,000 lbs)

Reliable power when and where you need it. Clean and simple.

Minimum Clearance Requirements⁽⁴⁾

Horizontal Clearance	
Left	1.5 m (60 in)
Right	0.0 m (0 in)
Front	1.7 m (65 in)
Rear	2.0 m (80 in)

Certifications

- UL 2200 Listed
- CE Certified
- Certified to the following grid interconnection standards: UL 1741, VDE, BDEW and CEI
- Compliant to California Rule 21 and New York State Public Service Commission

C200 Engine Components

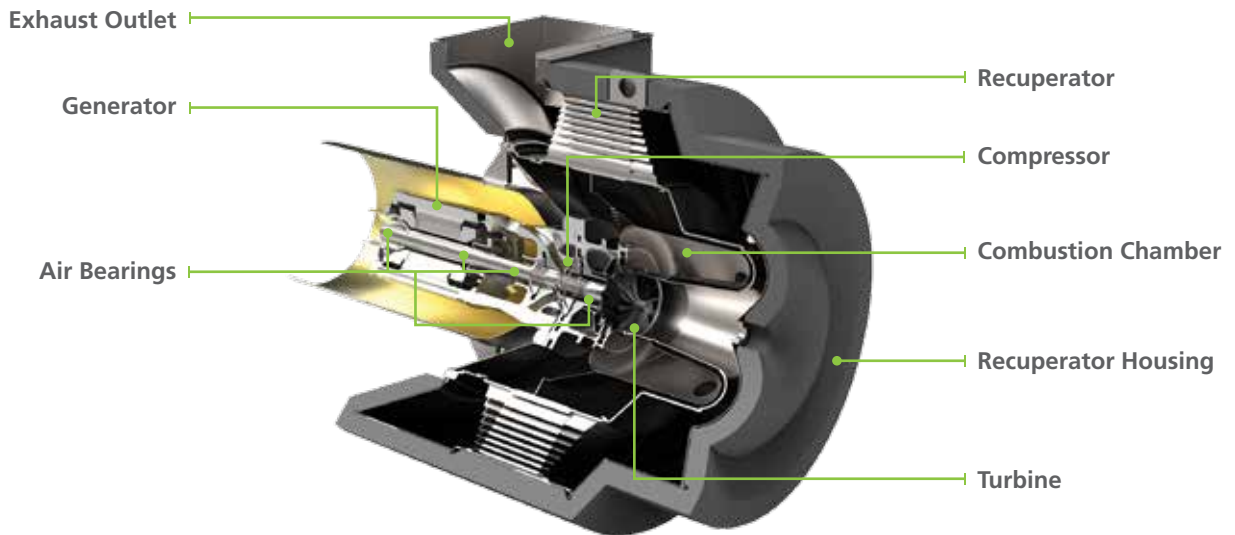

(1) Nominal full power performance at ISO conditions: 15°C (59°F), 14.696 psia, 60% RH

(2) Approximate dimensions and weights

(3) Height dimensions are to the roof line. Exhaust outlet extends at least 152 mm (6 in) above the roofline

(4) Clearance requirements may increase due to local code considerations

Specifications are not warranted and are subject to change without notice.

