

# C1000S Megawatt Power Package

## Digester Gas



The Signature Series Microturbine provides 1MW of reliable electrical power in one small, ultra-low emission, and highly efficient package.

- + Ultra-low emissions
- + Accepts sour gas fuels with up to 5,000 ppm H<sub>2</sub>S
- + One moving part – minimal maintenance and downtime
- + Patented air bearings – no lubricating oil or coolant
- + Integrated utility synchronization – no external switchgear
- + Compact modular design allows for easy, low-cost installation
- + High electrical efficiency over a very wide operating range
- + High availability – part load redundancy
- + Remote monitoring and diagnostic capabilities
- + Proven technology with tens of millions of operating hours
- + Various Factory Protection Plans available



C1000 Power Package

### Electrical Performance<sup>(1)</sup>

Electrical Power Output	1000kW
Voltage	400/480 VAC
Electrical Service	3-Phase, 4 Wire Wye
Frequency	50/60 Hz
Electrical Efficiency LHV	33%

### Fuel/Engine Characteristics<sup>(1)</sup>

Digester Gas HHV	20.5–32.6 MJ/m <sup>3</sup> (550–875 BTU/scf)
H <sub>2</sub> S Content	<5,000 ppm
Inlet Pressure	517–551 kPa gauge (75–80 psig)
Fuel Flow HHV	12,000 MJ/hr (11,400,000 BTU/hr)
Net Heat Rate LHV	10.9 MJ/kWh (10,300 BTU/kWh)

### Exhaust Characteristics

NO <sub>x</sub> Emissions @ 15% O <sub>2</sub>	< 9 ppmvd (18 mg/m <sup>3</sup> )
Exhaust Mass Flow	6.7 kg/s (14.7 lbm/s)
Exhaust Gas Temperature	280°C (535°F)

### Dimensions & Weight<sup>(2)</sup>

Width x Depth x Height	3.0 x 9.1 x 2.9 m (117 x 360 x 114 in)
Weight - Grid Connect Model	15,875 kg (35,000 lbs)
Weight - Dual Mode Model	20,100 kg (44,320 lbs)

*Reliable power when and where you need it. Clean and simple.*

## Minimum Clearance Requirements<sup>(3)</sup>

Horizontal Clearance	
Left	1.5 m (60 in)
Right	0.0 m (0 in)
Front	1.7 m (65 in)
Rear	2.0 m (80 in)

## Certifications

- UL 2200 Listed
- CE Certified
- Certified to the following grid interconnection standards: UL 1741, VDE, BDEW and CEI
- Compliant to California Rule 21 and New York State Public Service Commission

## C200 Engine Components

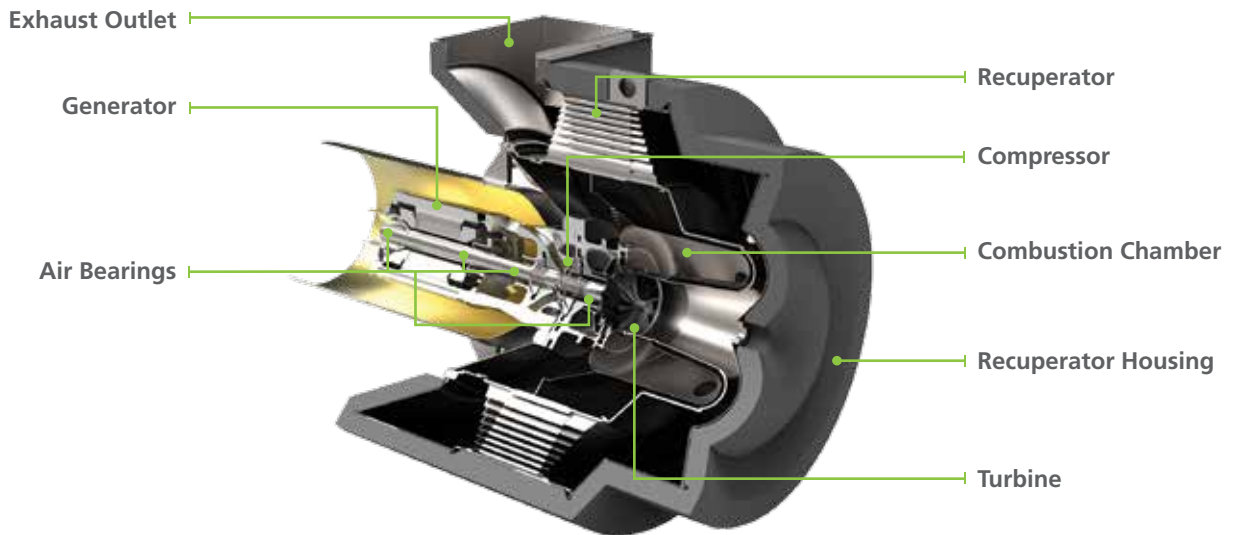

(1) Nominal full power performance at ISO conditions: 15°C (59°F), 14.696 psia, 60% RH

(2) Approximate dimensions and weights

(3) Clearance requirements may increase due to local code considerations  
Specifications are not warranted and are subject to change without notice.